



# POULTRY FEED SYSTEMS

---





# FEED BINS Bulk Feed Solutions

The heaviest grade of feed bins available on the market today. Longer lasting feed bins built with 5-10% more steel, by weight, than competitive brands. Built entirely of high tensile Structural Steel Grade 55 with a G100 galvanized finish. G100 bins have a galvanized coating that is 10% thicker than competitor brands, resulting in a longer lifespan.

Manufactured in-house for complete control of raw material purchasing and manufacturing operations. State-of-the-art rolling, stamping and finishing operations ensure precise fit and finish of feed bin components. Available in 6', 7', 9' and 12' diameter sizes.

In many locations, a local store offers assembly and delivery to your farm or building project.

## FEED BINS Capacity based on 40 lbs./Cubic Feet

\*Ladder kits must be purchased separately from feed bins.

\*All feed bins with a fill height exceeding 25' require purchase of ladder kit with safety cage.

ITEM #	TONS	CUBIC FEET	FILL HEIGHT (FT./IN.)	ITEM #	TONS	CUBIC FEET	FILL HEIGHT (FT./IN.)
<b>6 FT. DIAMETER FEED BINS WITH 60° HOPPER</b>				<b>9 FT. DIAMETER FEED BINS WITH 60° HOPPER</b>			
GST-616016K	3	150	11' 6"	GST-916016K	8.5	425	15' 7"
GST-626016K	4.5	225	14' 2"	GST-926016K	12	600	18' 3"
GST-636016K	6	300	16' 10"	GST-936016K	15	750	20' 11"
GST-646016K	7.5	375	19' 6"	GST-946016K	18.5	925	23' 7"
				GST-956016K	22	1100	26' 3"
				GST-966016K	25.5	1278	28' 11"
<b>7 FT. DIAMETER FEED BINS WITH 67° HOPPER</b>				<b>12 FT. DIAMETER FEED BINS WITH 60° HOPPER</b>			
GST-716716K	4.9	245	14' 9"	GST-1216016K	17.5	875	19' 5"
GST-726716K	6.9	345	17' 5"	GST-1226016K	23.5	1175	22' 1"
GST-736716K	9	450	20' 1"	GST-1236016K	29.5	1475	24' 9"
GST-746716K	11	550	22' 9"	GST-1246016K	35.5	1775	27' 5"
GST-756716K	13	650	25' 5"	GST-1256016K	41.5	2075	30' 1"
GST-766716K	15	750	28' 1"	GST-1266016K	47.5	2375	32' 9"



Model#: FEED BINS

Description: FEATURES

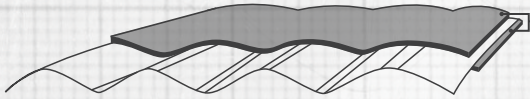

### G100 Galvanized Coating

Built entirely of high tensile Structural Steel Grade 55 with a G100 galvanized finish.

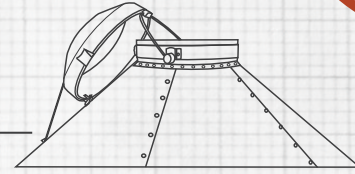

### Spring Lid with Locking Latch

Lid functions on a stainless steel pivot rod and slides down the side of the bin when opening. Spring design resists wind and helps keep precipitation out. Locking latch for easy servicing. Made of high density polyethylene with the best UV protection available.



### Weather Edge™

Improved Weather Edge™ design, with its extended 1-1/4" leg directs water away from the bin's hopper and boot.

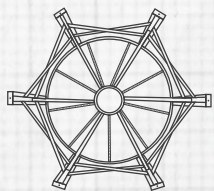

### Bottom Cone Sheets

Thicker and stronger bottom cone sheets resist dents and dings from mallets and hammers.

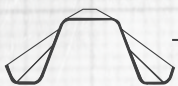

### Strong Base

10 & 12 gauge roll-formed legs provide a strong base.



### 40 Degree Roof

Laser cut roof sheets are rolled for precise fit. 40 Degree angle slope allows for maximum filling capacity.

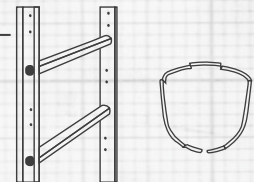

### Precision Stamped Ladder

Precision stamped ladder assembly with adjustable standard brackets. Rounded trapezoid ladder rung provides secure footing with a larger surface area. Design exceeds OSHA standards.

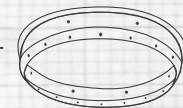

### Stamped 16" Bin Collar

Reduces variation in dimensions compared to rolled or spun collars. Constructed of 10 gauge metal, 4 gauges heavier than competitive brands.



**1) Clear Boot**

A simple glance will alert you to potential problems with feed delivery. Injection molded of impact-resistant clear polycarbonate. The GrowerSELECT replacement boot fits any 16" bin opening.

#HS525 .....Straight Clear upper boot

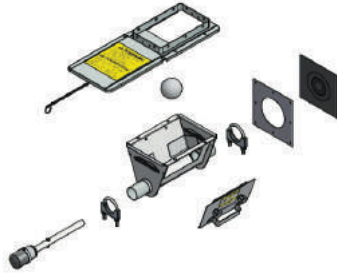

**2) Single Unloader with Anchor Bearings and Transfer Plate**

#HS520KIT .....Model 75  
#HS557KIT .....Model 90

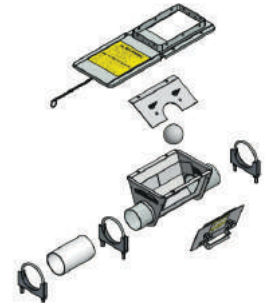

**3) Single Tandem Unloader with Transfer Plate**

#HS520TKIT .....Model 75  
#HS557TKIT .....Model 90



**4) 10' Straight PVC Tube**

#HSAT75-S .....Model 75, 3" OD  
#HSAT90-S .....Model 90, 3-1/2" OD



**5) 45° PVC Elbows, 5' Radius**

#HSAT75-45 .....Model 75  
#HSAT90-45 .....Model 90



**6) Grow-Flex™ Auger**

Our innovative manufacturing process forges a stronger, more durable auger with superior flexing and breaking strength that outperforms standard augers.

#HSFA-75 .....Model 75  
#HSFA-90 .....Model 90

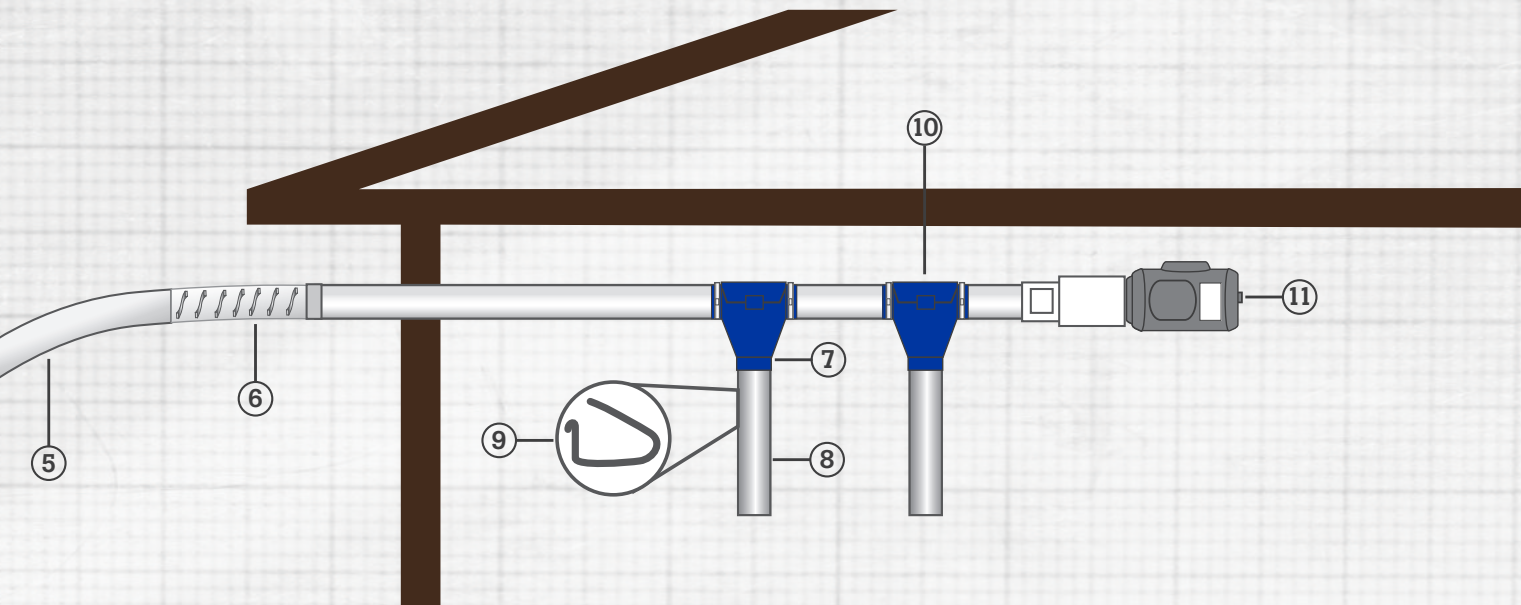

We've put 45 years of building, installing, and servicing livestock equipment into every GrowerSELECT Feed System and Feed Bin. Rugged high service factor motors, structurally heavier feed bins, and feed system components built to last longer with the industry's best warranty backed and serviced by local stores. Feed Systems built for your farm.



### 7) Drop Adaptors

- 100% Feed Drop Out
- Secure hose clamp connections with overlapping seams to prevent water entry.
- Fits existing brands of feed tubes.

#HS675.....M75/300  
 #HS690.....M90/350

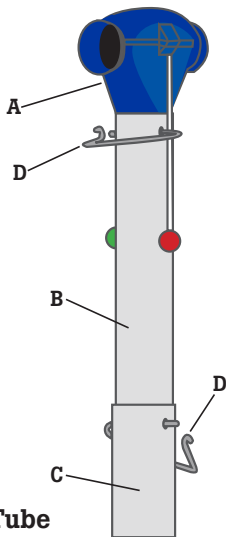

### 8) Drop Tube

Drop tube part number combinations that make up the telescoping drops.

- A - Drop Tube Adaptor
- B - Top Tube
- C - Bottom Tube
- D - Clips

MODEL	A	B	C	D	SINGLE TUBE
55	HS655	HSDT005	HSDT003	60638	HSDT005
75	HS675	HSDT005	HSDT003	60638	HSDT005
90	HS690	HSDT001	HSDT006	60638	HSDT001
HR	HS690	HSDT001	HSDT006	60638	HSDT001
Control Unit		HSDT001	HSDT006	60638	HSDT001

#HSDT006 .....4.187" ID x 4.375" OD x 12"



### 9) Wire Pin

#60638.....4" for attaching drop tubes



### 10) Control Unit

230 volt unit for all models. Includes drop cone.

#HS593 ..... Control Unit w/o Relay  
 #HS693 ...Control Unit w/ Relay for Proximity Switches



### 11) Direct Drive Power Units, 352 RPM

Complete with motor, gear heads, pinion, 36" pigtail cord and 15 oz. bottle of gear oil. All units are 115/208-230 volts.

#HS9022D2 .....3/4 Hp Model 75 & 90  
 #HS9023D2 ..... 1 Hp Model 75 & 90

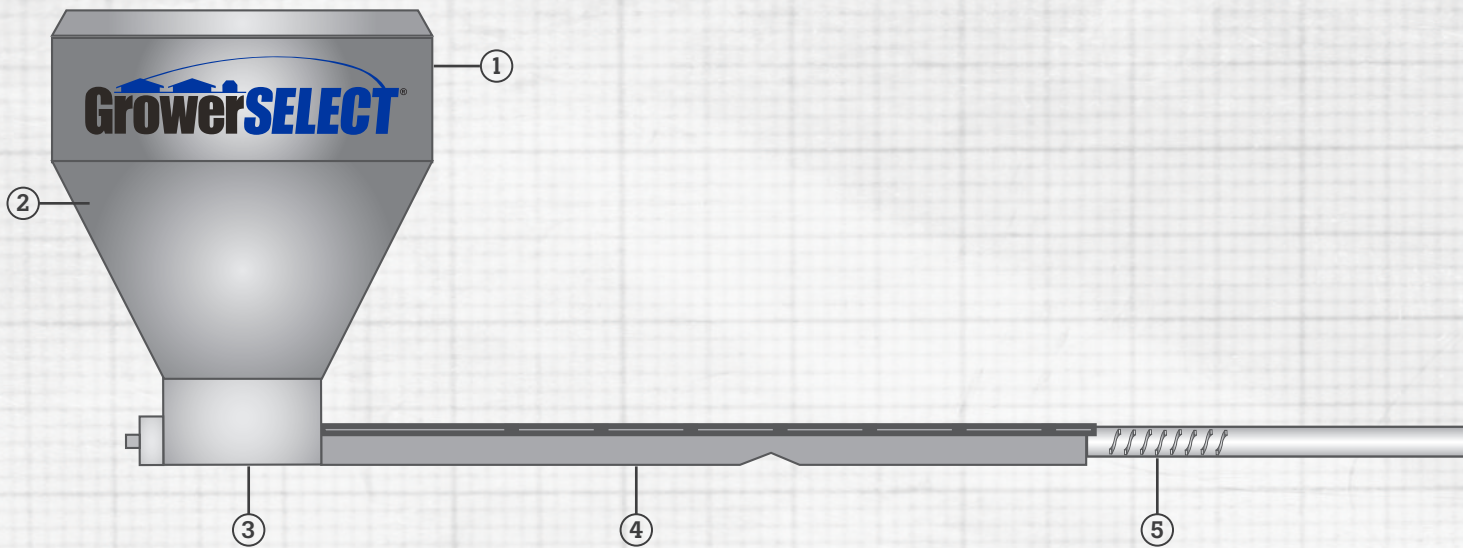

### 1) Feed Line Hoppers

20 ga galvanized feed hopper with Dual Point suspension mounted at right angle to prevent feedline sway. Can also be mounted with top single point suspension.

- #HS569A-120 ..... 120 lb
- #HS569A-200 ..... 200 lb
- #HS569A-300 ..... 300 lb



### 2) Hopper Level Control Switch

Fully enclosed "normally closed" switch eliminates shock hazard. Switch features adjustable arm to set feed depth and removable feed shield to adapt to different applications.

- #HS597 ..... Prewired "Normally Closed"  
110/220 Volt, 20 Amps max



### 3) Unloader Kits

Unloader kits for feed line hoppers, complete with cannonballs, anchor bearings, and hardware.

- #HS532KIT ..... Single Unloader Kit
- #HS533KIT ..... Double Unloader Kit



### 4) Feed Line Tube

Constructed of G90, rolled-formed galvanized steel, the GrowerSELECT® feedline tube is a standard 1.75" diameter. The seam features additional crimps per inch for additional strength and a deep 2" long swedged bell mouth.

- #HSPFT175-409 ..... 1.75 4 On 9
- #HSPFT175-410 ..... 1.75 4 On 10
- #HSPFT175-809 ..... 1.75 8 On 9
- #HSPFT175-810 ..... 1.75 8 On 10



### 5) Grow-Flex™ Auger

Our innovative manufacturing process forges a stronger, more durable auger with superior flexing and breaking strength that outperforms standard augers.

- #HSFA-44 ..... Flexible Auger 44mm



### 6) Intermediate Control Pan

Mid line control pan complete with 10' pigtail cord, 18" cord protector and 8 spoke grill. 115/230 volts with 20 amp micro switch, CSA Certified. Available as eight spoke grill only.

- #HS250 ..... Intermediate Control Pan

# GrowerSELECT<sup>®</sup>

## FEED SYSTEMS

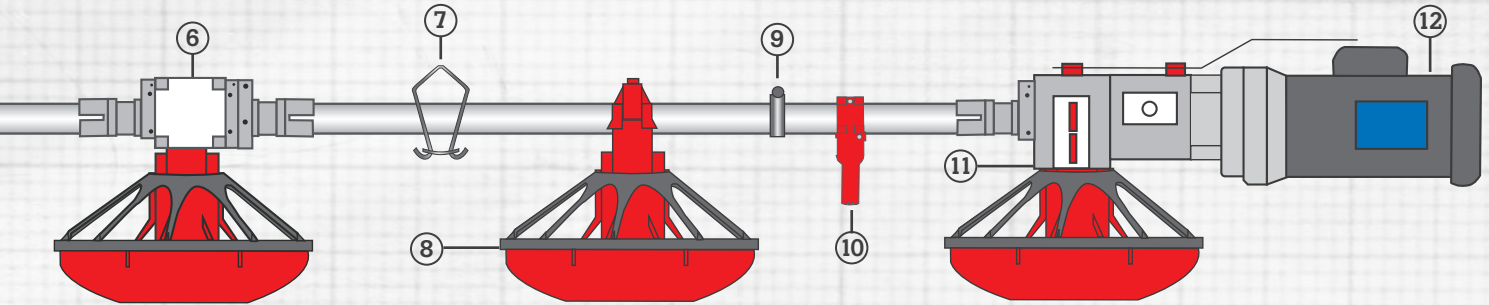

### 7) Feed Line Hanger

Unloader kits for feed line hoppers, complete with cannonballs, anchor bearings, and hardware.

- #HS022 .....Hanger Bracket
- #HS023 .....Hanger Bracket



### 8) Classic Flood Feed Pan

An improved version of an industry staple, the Classic Flood pan feeder is constructed of UV stabilized polypropylene without the use of CADMIUM or LEAD. Flood windows increase available feed in the pans to attract chicks and reinforced wear areas increase pan life.

- #HS8000 .....Classic Flood Feed Pan



### 9) Feed Line Clamp

For 1.75" pipe

- #HSH024 .....Hanger Clamp

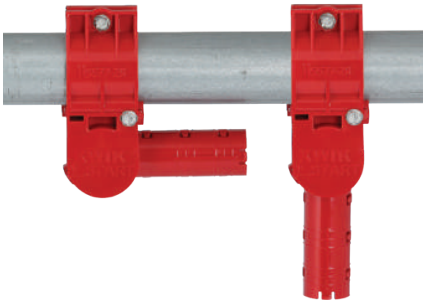

### 10) Kwik-Start

The only chick starter designed to allow complete feed shut off when using cone style sleeves. Choose from optional sleeves.

- #HS577 ..... Kwik Start only
- #HS578L ..... Cone Sleeve w/ Lock
- #HS577-325 .....3-1/4" Sleeve
- #HS577-600 ..... 6" Sleeve

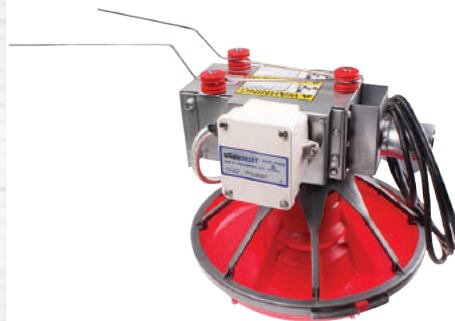

### 11) End Control Pan

Rugged, trouble-free design utilizes a simple paddle switch to control feed lines. Complete with 10' pigtail cord, 18" cord protector, water tight connections and 8 spoke grill. 115/230 Volts with 20 amp micro switch. CSA Certified. Available as eight spoke grill only.

- #HS8500 ..... End Control Pan



### 12) Drive Units

Complete with 115/230v motor, 352-rpm gear head, pinion, driver connection kit, gear oil and hardware. Includes 36" pigtail cord.

- #HS9020D1-P ..... 1/3 Hp
- #HS9021D1-P ..... 1/2 Hp
- #HS9022D1-P ..... 3/4 Hp

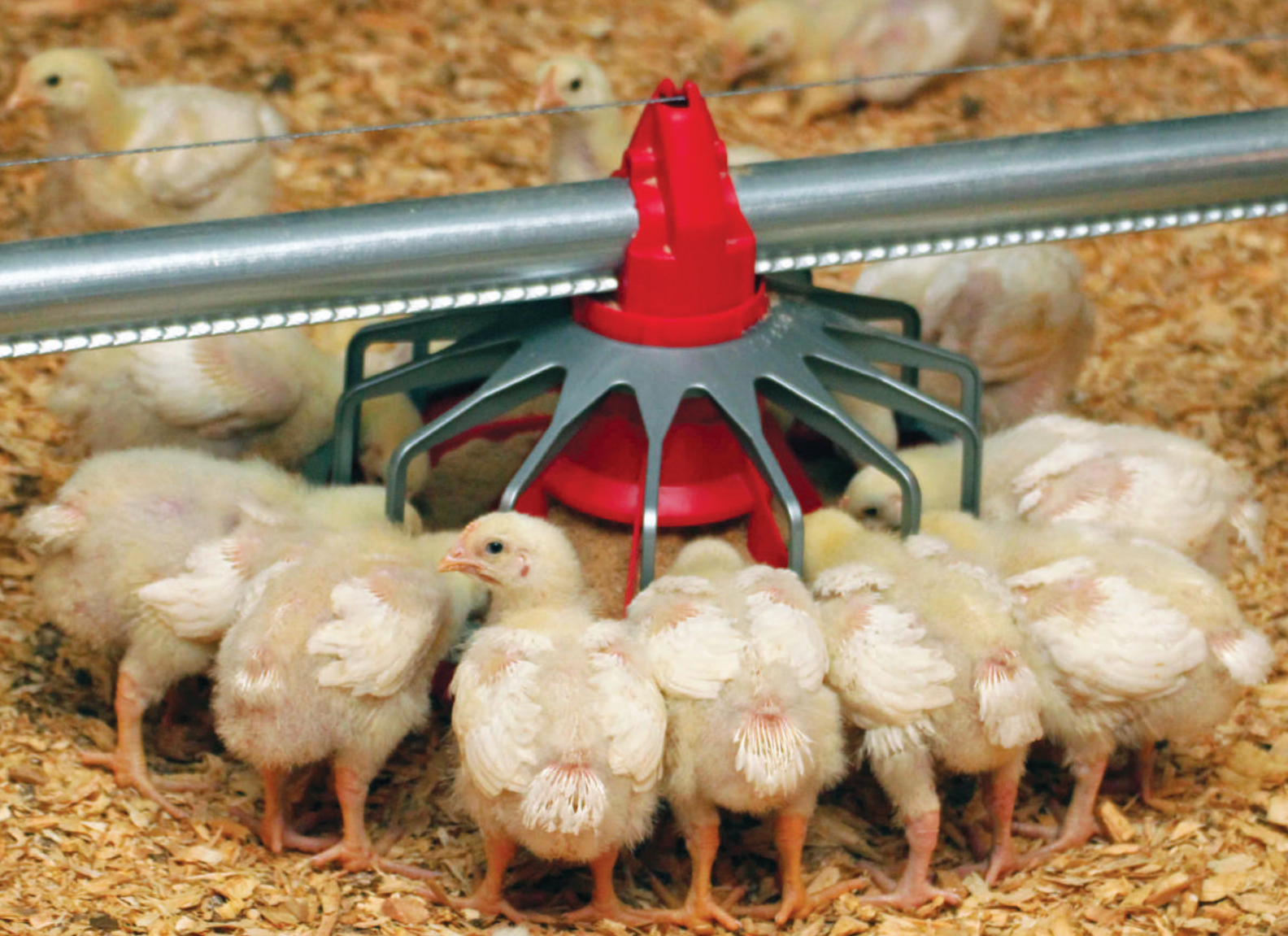

Grower**SELECT**  
**CLASSIC**  
HOUSLAVAT  
**FLOOD**

An improved version of an industry staple, the Classic Flood pan feeder is constructed of UV stabilized polypropylene without the use of CADMIUM or LEAD. Flood windows increase available feed in the pans to attract chicks and reinforced wear areas increase pan life. Even the warranty is improved.



	Model#: Classic Flood Pan Feeders
	Description: FEATURES

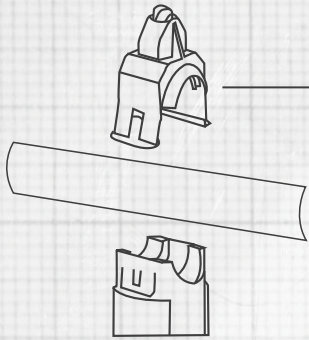

Optional two piece cone for installation on existing feed pipes.

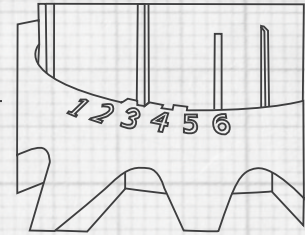

Easy to read Feed Level Indicator ensures each pan is set exactly the same and allows for adjustments as chicks grow.

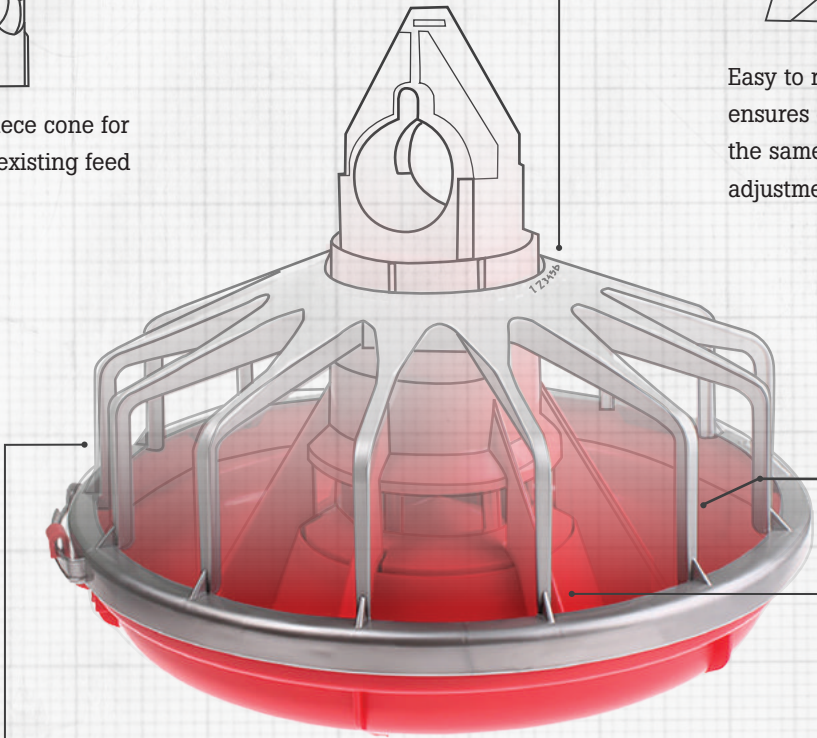

Specially designed flood windows increase available feed in the pan to attract chicks starting on feed.

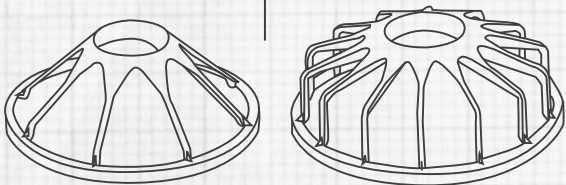

Optional 8 or 14 spoke grill.

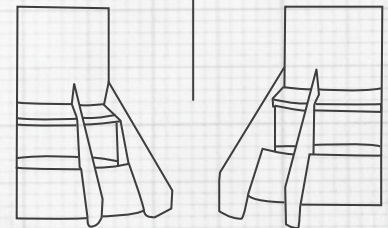

Standard or 1/2" longer extended fin. Extended fins keep the cone off the pan bottom maintaining feed flow.

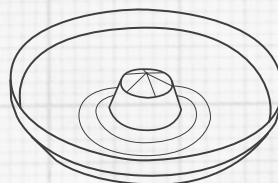

Reinforced wear areas in the pan add strength, leading to a longer lifespan.



“I FEEL LIKE I CAN BE  
COMPETITIVE WITH  
ANYBODY USING  
GROWERSELECT  
EQUIPMENT.”

## POULTRY GROWER COMPETITIVE WITH GROWERSELECT FEEDERS

---

When Billy Dossett decided to replace the 14-year-old feeding system in his broiler houses, he turned to Georgia Poultry to supply the equipment.

The Collins, Mississippi grower, explained, “We installed the GrowerSELECT Classic Flood feeders in two buildings and a leading competitive brand in two other buildings. In our five flock trial, the Classic Flood feeders came out on top four times.”

Billy continued, “The GrowerSELECT feed systems just haven’t given me any trouble, and the performance is great. I feel like I can be competitive with anybody using GrowerSELECT equipment. Maintenance costs have been reduced because of the lower cost of GrowerSELECT repair parts and I like having a stocked store close to me. The folks at Georgia Poultry have been there every time I needed something.”

# CLASSIC FLOOD FEEDER PARTS MATRIX



**#HS8000**  
14 Spoke Grill, Standard Fin,  
1 pc Drop Tube



**#HS8000A**  
8 Spoke Grill, Standard Fin,  
1 pc Drop Tube



**#HS8000B**  
14 Spoke Grill, Extended Fin,  
1 pc Drop Tube



**#HA8000C**  
8 Spoke Grill, Extended Fin,  
1 pc Drop Tube

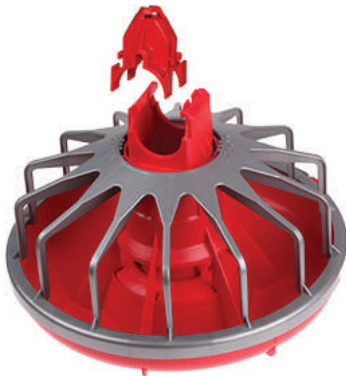

**#HS8000D**  
14 Spoke Grill, Standard Fin,  
2 pc Drop Tube



**#HA8000E**  
8 Spoke Grill, Standard Fin,  
2 pc Drop Tube



**#HS8000F**  
14 Spoke Grill, Extended Fin,  
2 pc Drop Tube



**#HS8000G**  
8 Spoke Grill, Extended Fin,  
2 pc Drop Tube



Two-piece cone retrofits existing feed lines.

## AVAILABLE TO FIT 45MM SMOOTH PIPE

ITEM#	DESCRIPTION
HS8000I	8 spoke grill, standard fin, shallow pan, 2 piece, 45mm drop tube
HS8000M	14 spoke grill, standard fin, shallow pan, 2 piece, 45mm drop tube
HS8000O	14 spoke grill, extended fin, shallow pan, 2 piece, 45mm drop tube

## SUPPORT CONES

ITEM#	DESCRIPTION
A) HS8000-10	Removable top for 45mm support cone
B) HS8000-9	Support cone for 45mm tube



**PANS**

ITEM#	DESCRIPTION
A) HS8000-7	Pan w/ shallow cone
B) HS8000-1	Pan w/ standard cone



**ADJUSTERS**

ITEM#	DESCRIPTION
E) HS8000-3F	Adjuster for extended fin
F) HS8000-3	Adjuster for standard fin



**GRILLS**

ITEM#	DESCRIPTION
C) HS8000-8	8 spoke grill
D) HS8000-2	14 spoke grill



**SUPPORT CONES**

ITEM#	DESCRIPTION
G) HS8000-4	Support cone for standard fin
H) HS8000-4F	Support cone for extended fin



**SUPPORT CONE & REMOVABLE TOP**

ITEM#	DESCRIPTION
I) HS8000-5R	Support cone w/o removable top
J) HS8000-6R	Removable top for support cone



**LIGHT KIT**

Light kit for any Classic Flood end control pan. Six powerful, long-lasting LED lights illuminate the control pan attracting birds. This leads to increased feed line run times, resulting in fuller pans. The light kit mounts under the control unit to reduce shading and shadows. Includes light plate and integrated wiring assembly.



ITEM#	DESCRIPTION
HS8500L	LED Light Kit



**INTERMEDIATE CONTROL PAN**

Mid line control pan complete with 10' pigtail cord, 18" cord protector and 8 spoke grill. 115/230 volts with 20 amp micro switch, CSA Certified. Available as eight spoke grill only.

ITEM#	DESCRIPTION
HS8250	Intermediate Control pan



**END CONTROL PAN**

Rugged, trouble-free design utilizes a simple paddle switch to control feed lines. Complete with 10' pigtail cord, 18" cord protector, water tight connections and 8 spoke grill. 115/230 Volts with 20 amp micro switch. CSA Certified. Available as eight spoke grill only.

ITEM#	DESCRIPTION
HS8500	End Control Pan

# G-LOGIC CONTROL PAN

Control pan features a non-mechanical sensor to detect feed levels for increased reliability. Complete with 10' pigtail cord, 18" cord protector, watertight connections and 8 spoke grill. 115/ 230 volt. Available as eight spoke grill only.

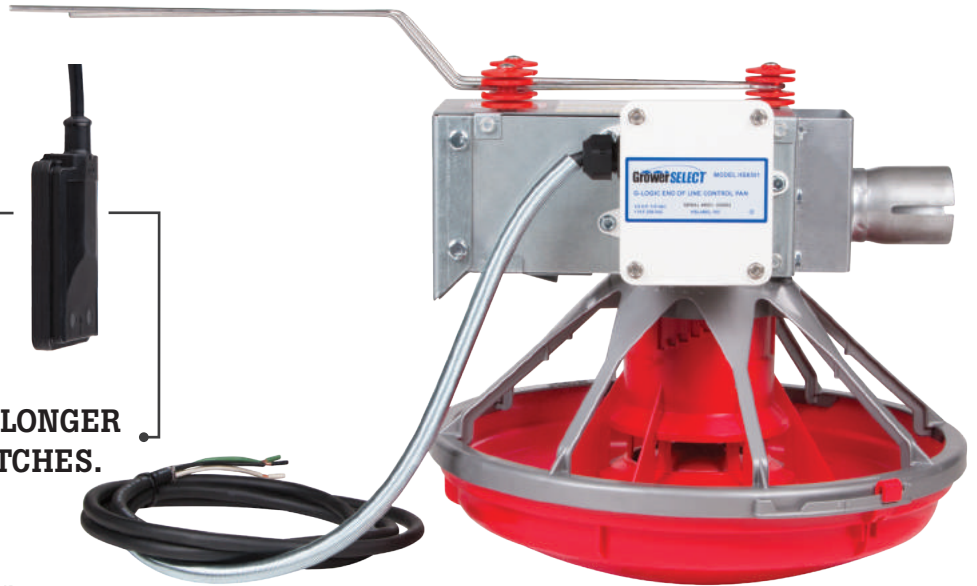
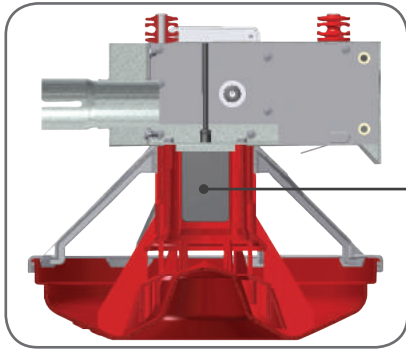

**THE CAPACITIVE SENSOR LASTS LONGER THAN MECHANICAL PADDLE SWITCHES.**

- No moving parts to wear out.
- No fabric diaphragms to replace.
- Circuit protection to safeguard against voltage spikes.
- 60 second time delay to reduces motor short cycling.
- Internal compensation to prevent fluctuating temperatures from influencing the unit's sensitivity.

ITEM#	DESCRIPTION
HS8501	G-Logic Control Pan



Note clearance between the cone sleeve and feed line. This clearance allows the drop tube to come to a complete right angle assuring complete feed shutoff. Drops will not loosen and fall down over time. When installing any chick starter be sure to install it so that the drop folds up towards the fan end of the house.

Manufactured from high quality NYLON to prevent breakage. Sleeves are constructed of chemical resistant polypropylene. Installs easily on existing feed lines.

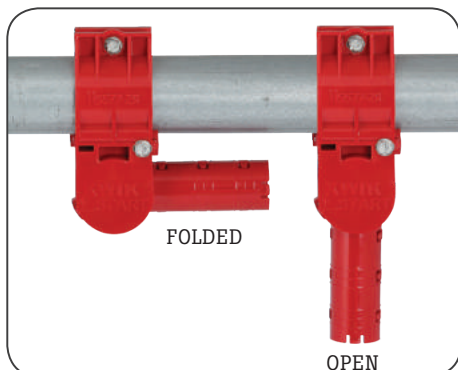

Choose from optional sleeves\* to accommodate varying feed line heights.

ITEM#	DESCRIPTION
HS577	Kwik Start Chick Feeder
1) HS578L	Cone Sleeve w/ Lock
2) HS577-325	3.25" Sleeve
3) HS577-600	6" Sleeve

\*Sleeves are excluded from GrowerSELECT 2-Year warranty.

**GrowerSELECT®**  
**Adult Turkey**  
**Feeder #HST1000**



**THE CAPACITIVE SENSOR LASTS LONGER THAN MECHANICAL PADDLE SWITCHES.**

- No moving parts to wear out.
- No fabric diaphragms to replace.
- Circuit protection to safeguard against voltage spikes.
- 60 second time delay to reduces motor short cycling.
- Internal compensation to prevent fluctuating temperatures from influencing the unit's sensitivity.



**The G-Logic Control Pan** utilizes a reliable non-mechanical sensor to detect the feed level.

**#HST1500**



Model#: HST1000

Description: FEATURES

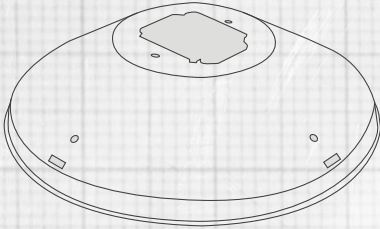
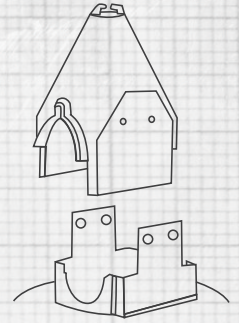

Heavy-duty galvanized shield designed to withstand large birds.



Square, free-swinging, steel drop tube allows feeder to move to reduce bruising.

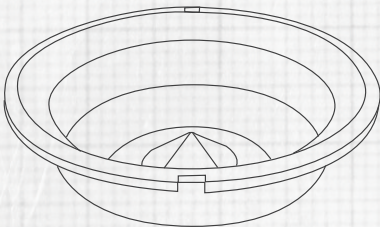

Robust polypropylene feed pan features classic deep V design with feed saver lip. Reinforced pan stands up to even the most aggressive birds.

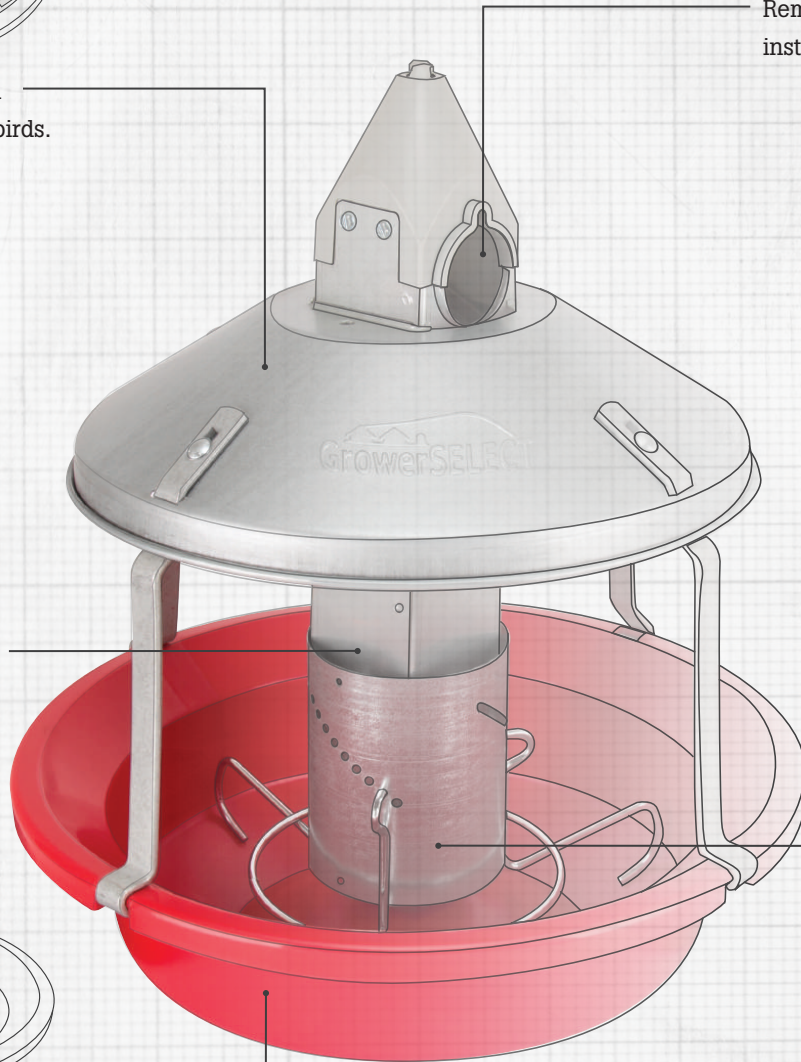

Removable, two-piece top aids installation and replacement.



Flue ring adjustment permits accurate control of feed level to prevent waste. Molded cone in pan distributes feed for 360° bird access.

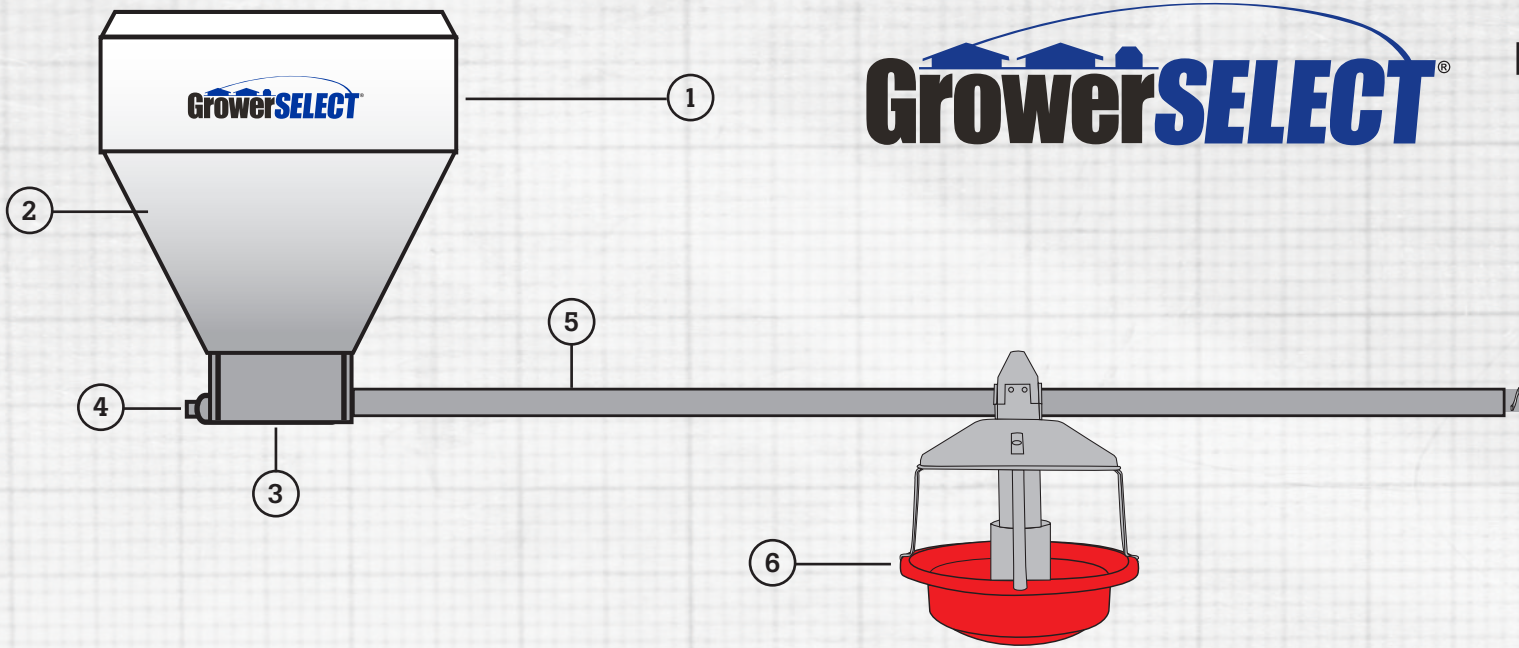

## 1) Feed Line Hoppers

20 ga. galvanized feed hopper with Dual Point suspension mounted at right angle to prevent feedline sway. Can also be mounted with top single point suspension. Ships unassembled.



- #HS569A-200 ..... 200 lb
- #HS569A-300 ..... 300 lb

## 2) Hopper Level Control Switch

Fully enclosed "normally closed" switch eliminates shock hazard. Switch features adjustable arm to set feed depth and removable feed shield to adapt to different applications. Prewired "Normally Closed" 110/220 Volt, 20 Amps max.



- #HS597 ..... Hopper Level Control Switch

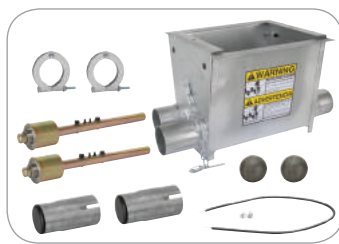

## 3) Unloader Kits

- #HST1610KIT ..... Single Unloader Kit
- #HST1600KIT ..... Twin Unloader Kit

## 4) Anchor Bearing

- #HSTAB45 ..... Turkey Anchor Bearing



## 5) Turkey Tube

- #HSPFT200-110 ..... Tube Turkey, 2", 1 on 10" (80" spacing)
- #HSPFT200-210 ..... Tube Turkey, 2", 2 on 10" (60" spacing)
- #HSPFT200-210L ..... Tube Turkey, 2", 2 on 10" (80" spacing)
- #HSPFT200-310 ..... Tube Turkey, 2", 3 on 10" (40" spacing)

## 6) Adult Turkey Feeder

- #HST1000 ..... Adult Turkey Feeder





# Turkey Feed Systems

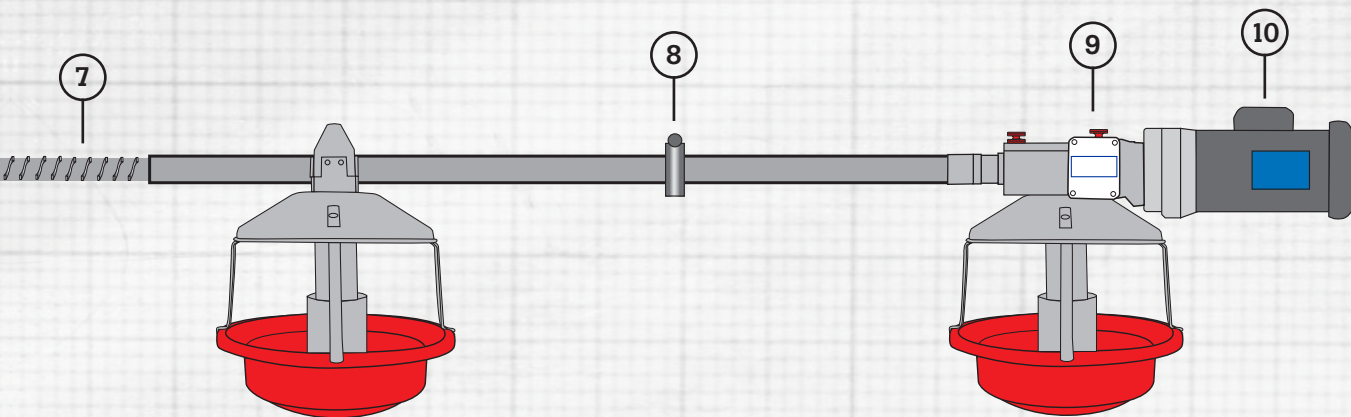

## 7) Grow-Flex™ Auger

Our innovative manufacturing process forges a stronger, more durable auger with superior flexing and breaking strength that outperforms standard augers.

#HSFA-44 ..... Flexible Auger 44mm



## 8) Feed Line Clamp

#HST500 ..... 2" Feed line clamp



## 9) End Control Pan

#HST1500 ..... End control pan



## 10) Drive Units

Complete with 115/230v motor, 352-rpm gear head, pinion, driver connection kit, gear oil and hardware. Includes 36" pigtail cord.

#HS9020D1-P ..... 1/3 Hp

#HS9021D1-P ..... 1/2 Hp



## Boot Weldments

#HST1610 ..... Single Boot Weldment, Turkey

#HSTHSAT1600 ..... Double Boot Weldment, Turkey



## Insulator Kit

#HST1734 ..... Insulator Kit, Turkey

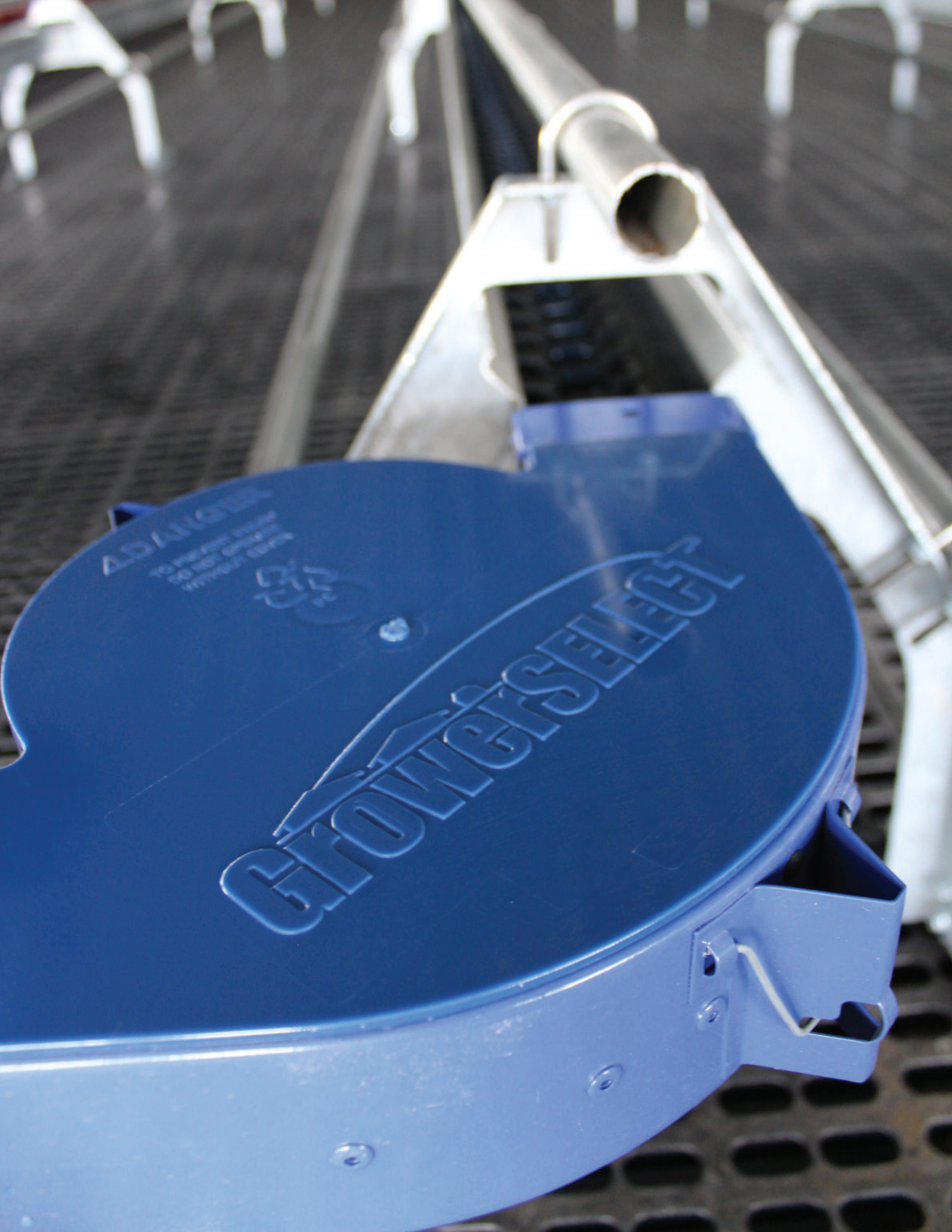

DANGER  
To keep your hands safe,  
use proper grip and  
technique.

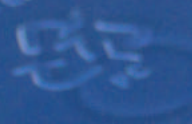

Grower's Select

	Model#: HSFC2
	Description: FEATURES

**Galvanized Trough**

Roll formed trough, manufactured from 18 gauge, G90 commercial grade galvanized steel.

**Sealed Bearing**

Completely sealed bearing, no greasing required.

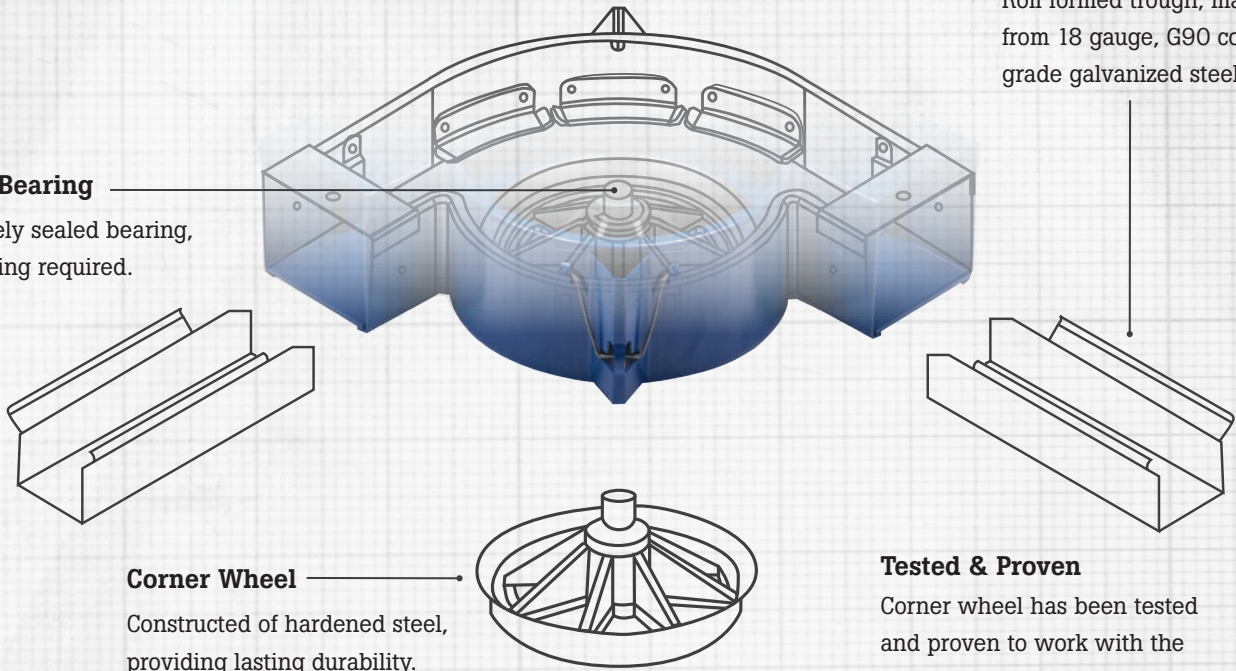

**Corner Wheel**

Constructed of hardened steel, providing lasting durability.

**Tested & Proven**

Corner wheel has been tested and proven to work with the GrowerSELECT feed chain.



**REPLACEMENT FEED CHAIN**

ITEM #	DESCRIPTION
HSFC-1	50' Rolls Only



**90° CORNER**

ITEM #	DESCRIPTION
HSFC2	90° Corner w/suspension hanger



**HANGER SUSPENSION**

ITEM #	DESCRIPTION
HSFC3	Hanger Suspension Chain Feed

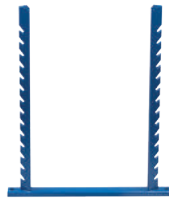

**STAND CORNER**

ITEM #	DESCRIPTION
HSFC4	14" wide x 16-1/2" high



**COUPLER**

ITEM #	DESCRIPTION
HS656	8" Medium wide



**TROUGH**

ITEM #	DESCRIPTION
HS618-10	Medium wide, 10' long for hens
HS618-12	Medium wide, 12' long for hens



[www.gapoultry.com](http://www.gapoultry.com)

1-800-949-4647

©2017 Hog Slat, Inc. All rights reserved.