

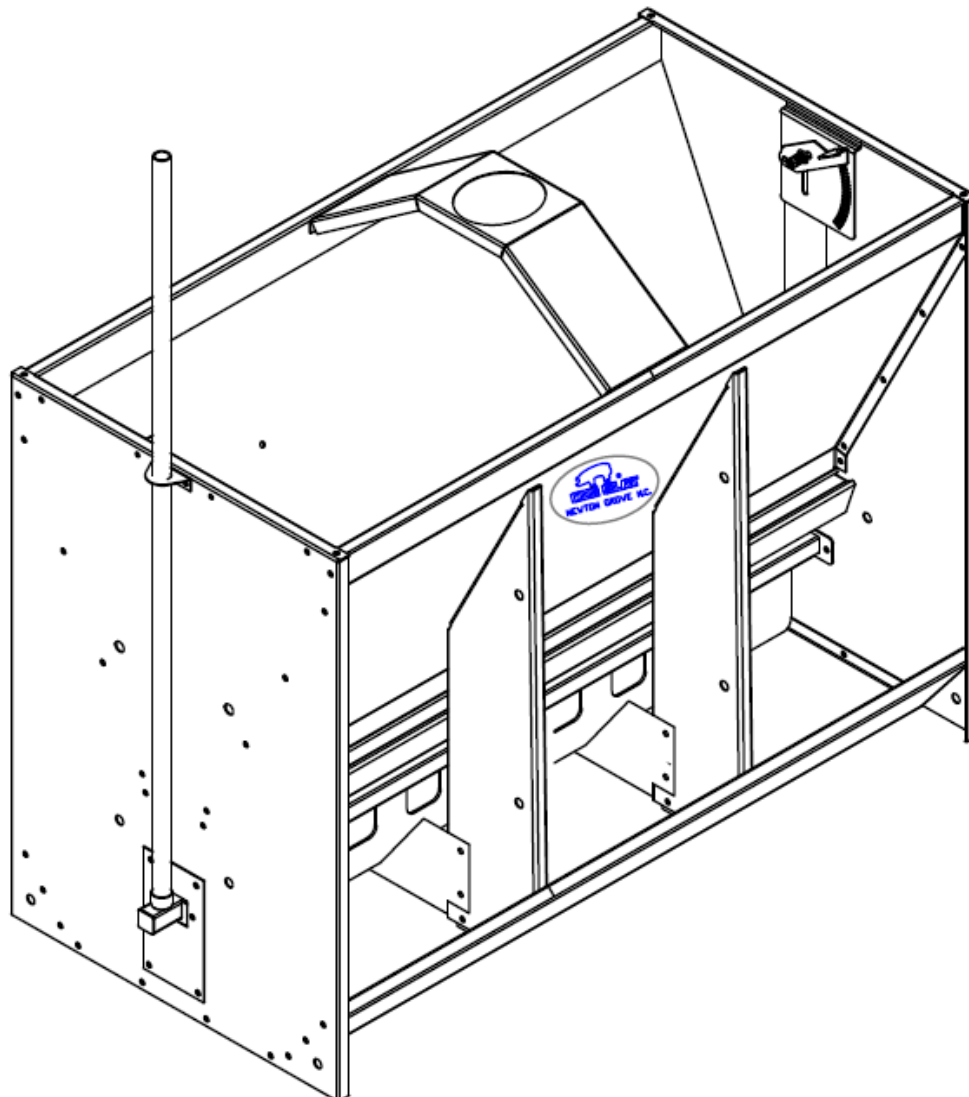

Wet/Dry Feeder Bolted 45" X 31" Adjustment Plate Assembly Instructions (Includes Spanish Version)

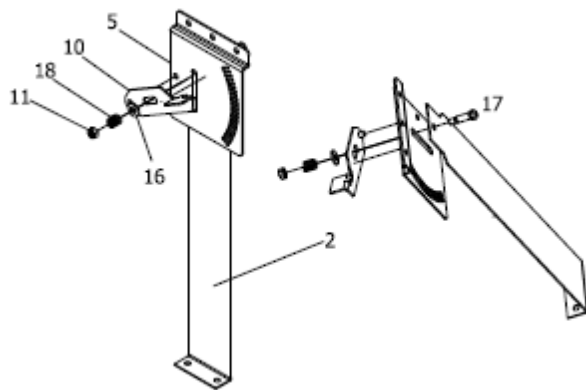

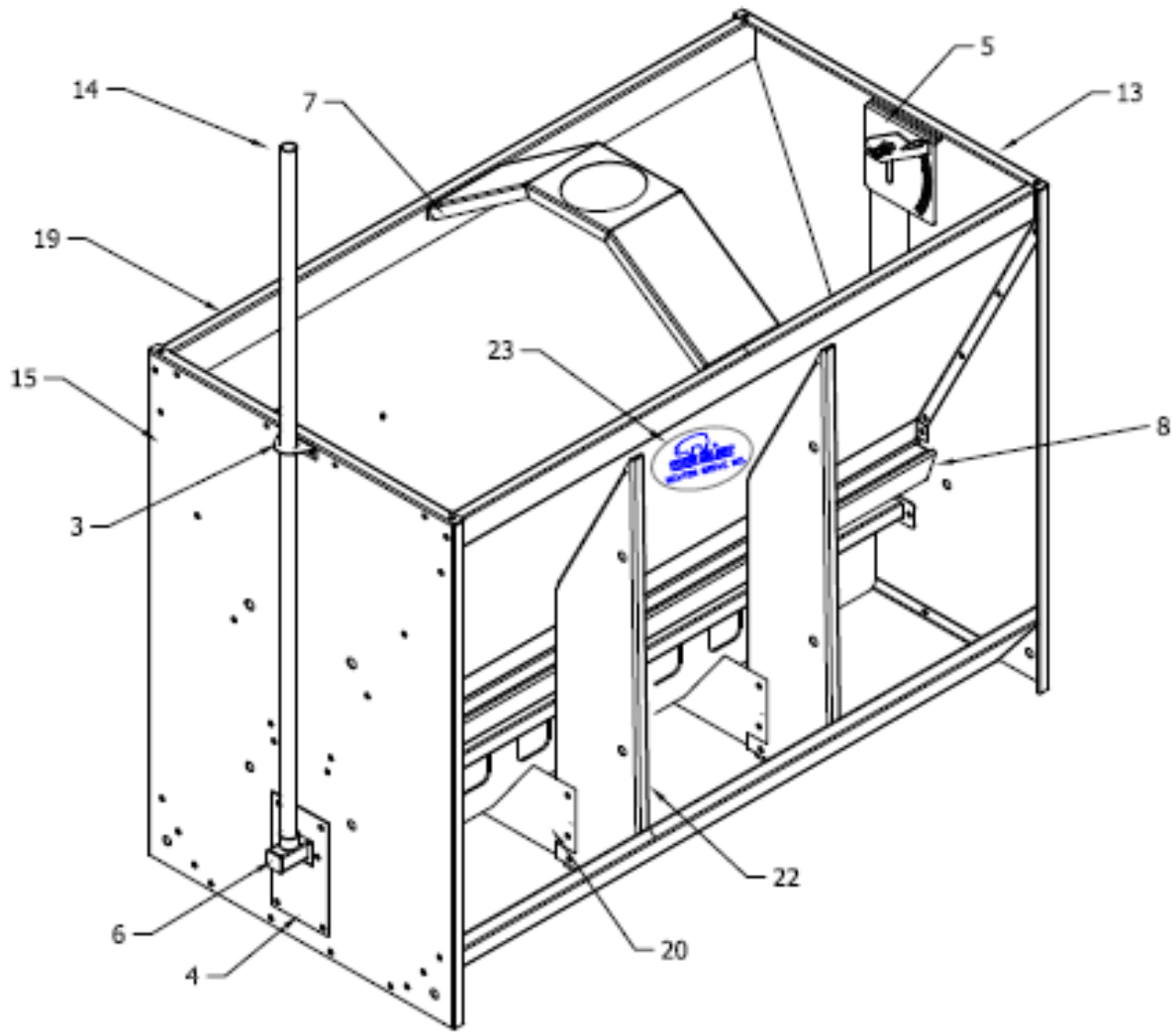

Apply grease to mated surfaces.
Tighten locknut till nylon is past threads on bolt.

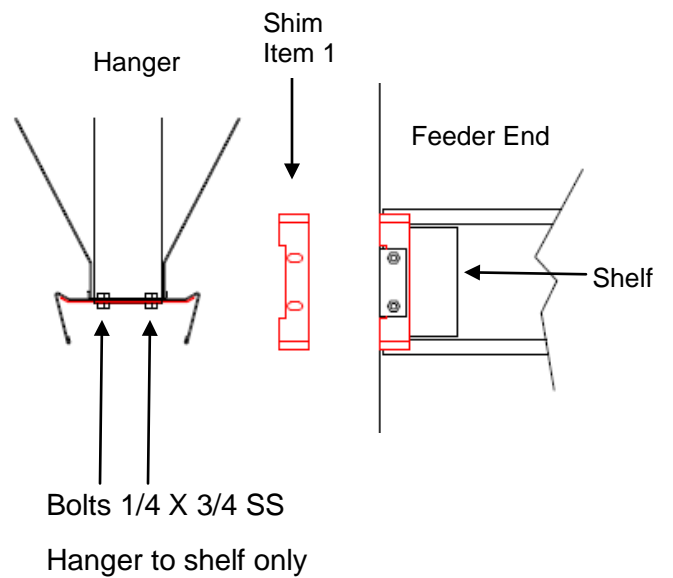

Item	Part Number	Description	Quantity
1	766-410-05-00	Wet/Dry Adjustment Shim	2
2	766-421-05-00	Wet/Dry Shelf Hanger	2
3	766-391-05-00	Wet/Dry Water Pipe Holder (Bent)	1
4	766-390-05-01	Wet/Dry End Cap (Punch)	1
5	766-850-05-00	Wet/Dry Adjustment Plate (Bent)	2
6	745-901-05-02	45" Wet/Dry Water Tube with Plug	1
7	766-800-05-00	Wet/Dry Cross Brace (Bent)	1
8	745-430-05-00	45" Wet/Dry Shelf (Spot Weld)	1
9	745-210-15-00	Bottom Welded	1
10	766-856-05-00	Wet/Dry Lever (Weld)	2
11	960-250-25-00	Hardware Locknut 1/4 SS	108
12	940-312-25-00	Hardware Bolt 1/4 X 1/2 SS	102
13	766-314-05-00	Wet/Dry End Closed End	1
14	815-402-05-00	48" SS Pipe Thread Both Ends	1
15	766-312-05-00	Wet/Dry End with Opening	1
16	950-312-05-00	Hardware Flat Washer 5/16 SS	2
17	940-250-21-09	Shoulder Bolt 5/16 X 3/4	2
18	740-895-05-00	Spring SAF05 .480 X .063 X .875 SS	2
19	745-110-05-00	Side 45" X 31"	2
20	766-650-05-01	Wean Blocker	2
21	940-312-25-01	Bolt 1/4 X 3/4 SS	4
22	766-610-05-01	Bolt in Divider	4
23	730-994-00-00	Feeder Label	2

Assembling

Assemble adjustment to ends tight.

Snug bolts through hanger, shim, and shelf.

Place lever in (0) position before tightening bolts in side.

Side should sit flush to shelf.

Recheck shim and hanger placement to ends and tighten shelf.

All bolts are 1/4" X 1/2" except on shelf to hanger (they are 1/4" X 3/4").

All bolts and locknuts are stainless steel.

This equipment must be installed in accordance with all State and Local Codes and applicable Regulations which should be followed in all cases. Authorities having jurisdiction should be consulted before installations are made.



**Hog Slat, Inc.
PO Box 300
Newton Grove, NC 28366**

**Phone: (910) 594-0219
Fax: (910) 594-1392**

www.hogslat.com

Copyright © 2016 by Hog Slat, Inc.

Part Number: HSMANUAL-116 REV IR



Comedero Húmedo/Seco Atornillado 45" X 31"

Instrucciones de Montaje de la Placa de Ajuste

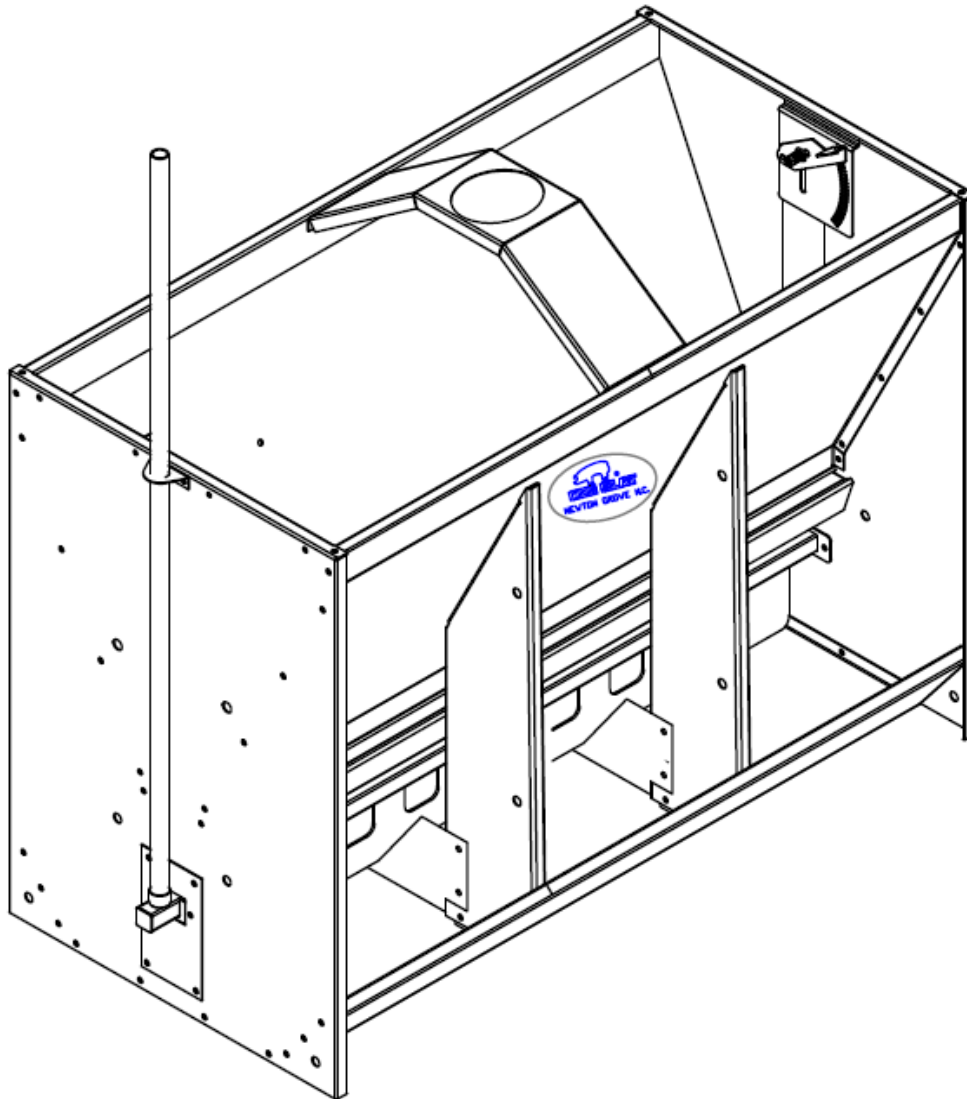

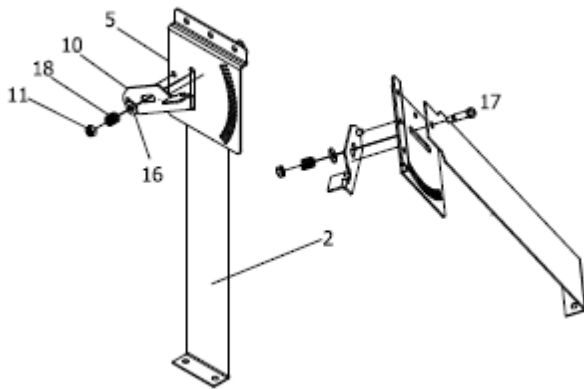
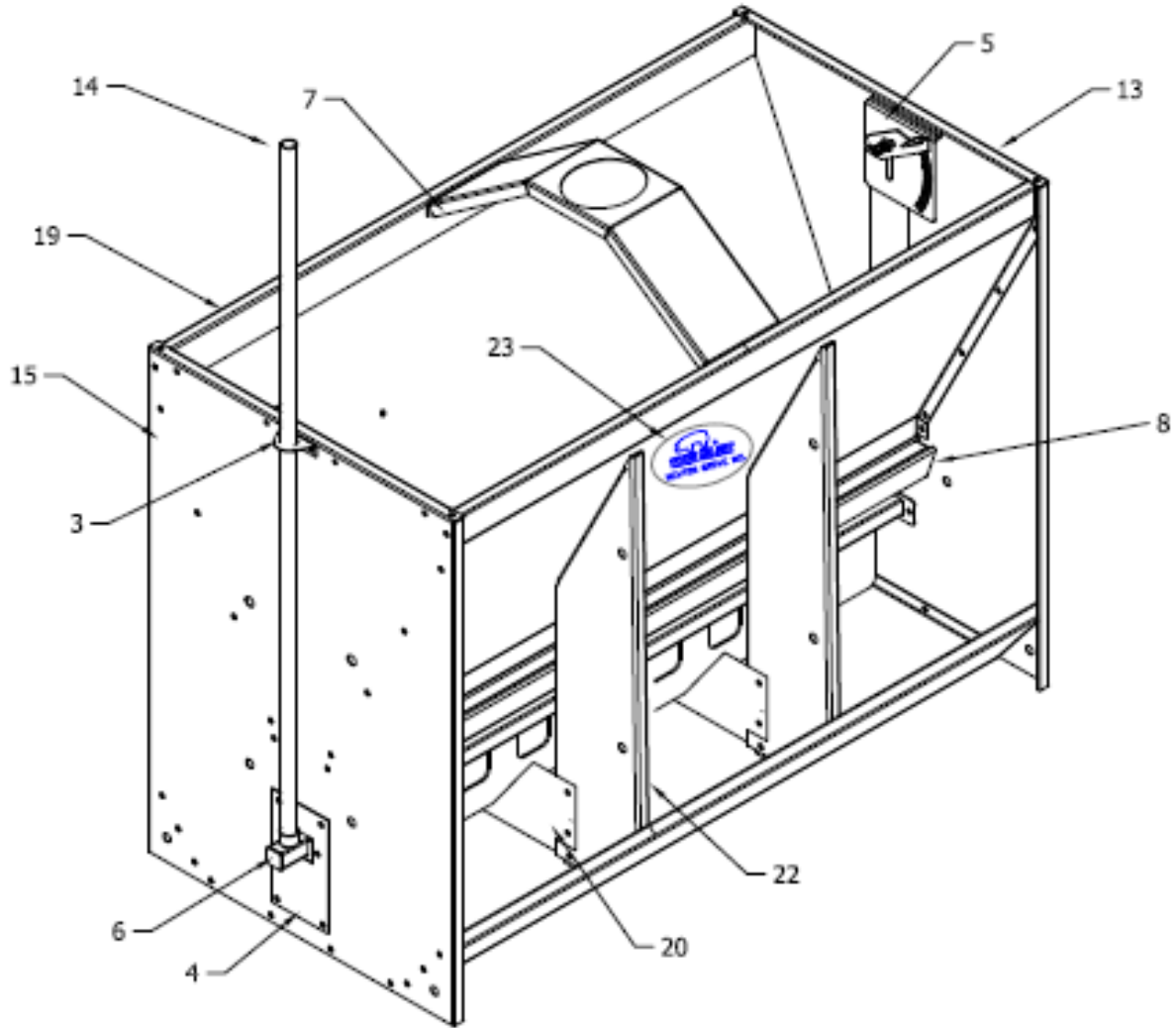

Aplique grasa a las superficies apareadas
 Apriete la tuerca de seguridad hasta que el nylon
 haya pasado las roscas del tornillo

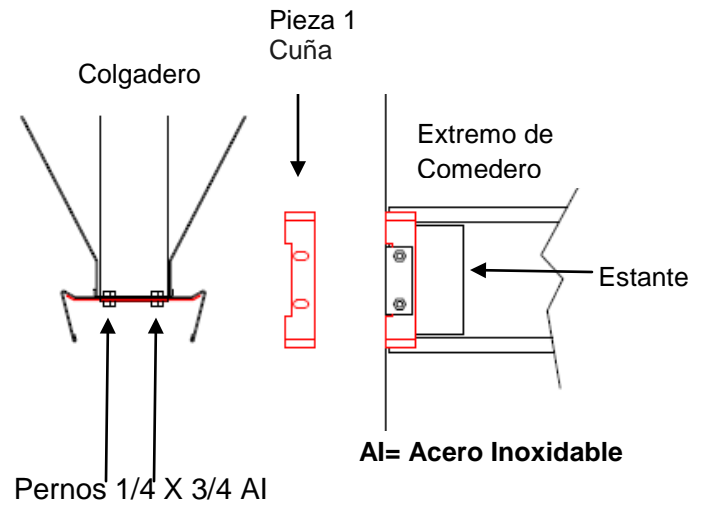

De colgadero a estante solamente

Pieza	Numero de Parte	Descripcion	Cantidades
1	766-410-05-00	Cuña de ajuste - húmedo / seco	2
2	766-421-05-00	Colgadero de Estante - húmedo / seco	2
3	766-391-05-00	Soporte de Tubería de Agua (doblado) - húmedo / seco	1
4	766-390-05-01	Tapón de extremo (perforado) - húmedo / seco	1
5	766-850-05-00	Plato de Ajuste (Doblado) - húmedo / seco	2
6	745-901-05-02	Tubo de Agua con Tapón de 45"- húmedo / seco	1
7	766-800-05-00	Soporte Cruzado (Doblado) - húmedo / seco	1
8	745-430-05-00	Estante de 45"-- húmedo / seco (Puntos de Soldadura)	1
9	745-210-15-00	Fondo Soldado	1
10	766-856-05-00	Palanca niveladora - húmedo / seco (Soldada)	2
11	960-250-25-00	Tornillería-Tuerca de bloqueo 1/4 AI	108
12	940-312-25-00	Tornillería-Perno 1/4 X 1/2 AI	102
13	766-314-05-00	Extremo Cerrado Final - húmedo / seco	1
14	815-402-05-00	Tubo con Rosca en ambos extremos 48" AI	1
15	766-312-05-00	Extremo con Abertura - húmedo / seco	1
16	950-312-05-00	Tornillería- Arandela Plana 5/16 AI	2
17	940-250-21-09	Perno (con sección sin rosca) de 5/16 X 3/4	2
18	740-895-05-00	Resorte SAF05 .480 X .063 X .875 AI	2
19	745-110-05-00	Extremo 45" X 31"	2
20	766-650-05-01	Bloqueador de Destete	2
21	940-312-25-01	Perno 1/4 X 3/4 AI	4
22	766-610-05-01	Perno en Divisor	4
23	730-994-00-00	Etiqueta de Comedero	2

AI= Acero Inoxidable

Montaje

Montar ajuste a los extremos firmemente.

Ajustar los pernos a través del colgador, cuña y estante.

Posicionar nivelador en la posición (0) antes de apretar los pernos en extremo.

Lado debe estar a nivel con el estante.

Volver a revisar cuña y colocación del colgador a los extremos y apretar el estante.

Todos los pernos son de 1/4" X 1/2" excepto en el del estante al colgador (esos son de 1/4" X 3/4").

Todos los pernos y tuercas de bloqueo son de acero inoxidable.

Este equipo debe ser instalado de acuerdo con todos los códigos estatales y locales y reglamentos aplicables que deben seguirse en todos los casos. Las autoridades competentes deben ser consultadas antes de que se efectúen las instalaciones.



Hog Slat, Inc.
PO Box 300
Newton Grove, NC 28366

Phone: (910) 594-0219
Fax: (910) 594-1392

www.hogslat.com

Copyright © 2016 by Hog Slat, Inc.

Part Number: HSMANUAL-116 REV IR